

Symmetry Locking Device

Safe and Seamless

This Symmetry lock solution, designed specifically for the home elevator market, provides peace of mind and out of sight installation.



Flush door frame with key cover (door and frame by others)



Latch mounted in door slab



Symmetry Locking Device mounted in door frame

Flush Door Frame for Symmetry Locking Device

ASME A17.1 Compliant, Meets the 3/4" x 3" and 3/4" x 4" Rule*

The Symmetry Flush Door Frame prepped for the Symmetry Locking Device (SLD) provides a code compliant, safe and unobtrusive solution that essentially eliminates the gap between the hoistway landing door and the elevator gate.

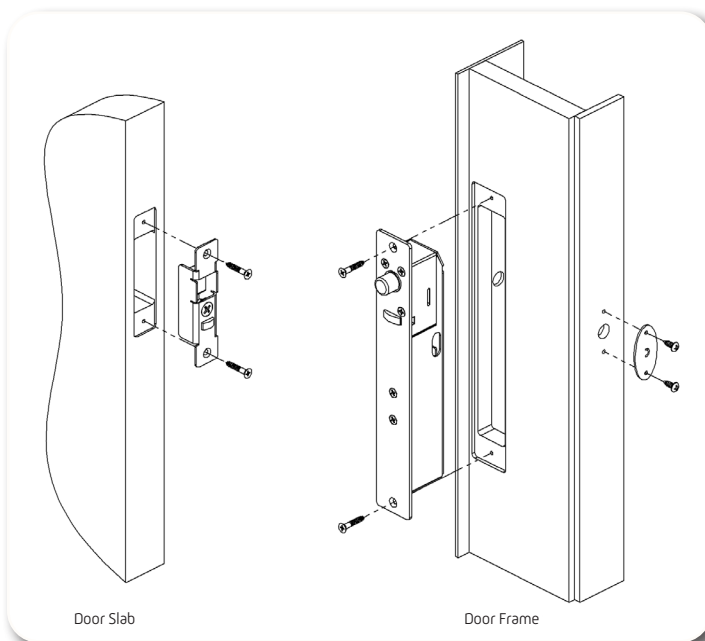

Symmetry Locking Device detail

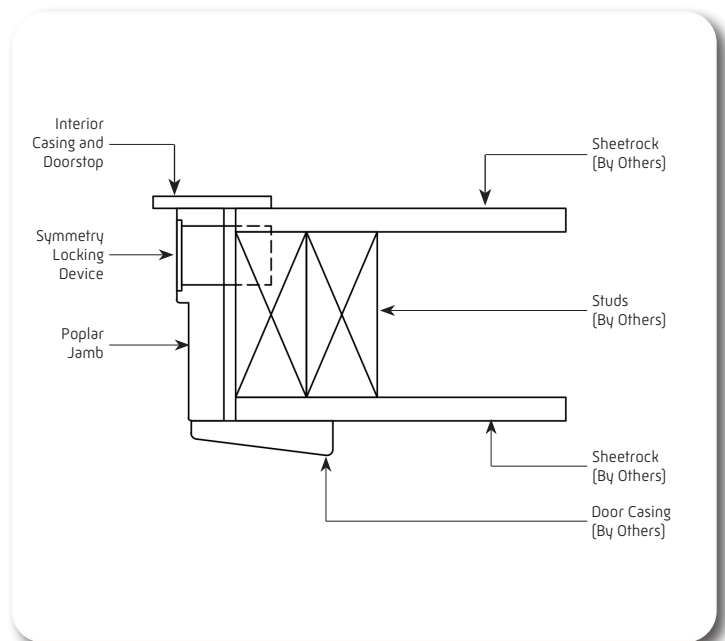

Flush door frame for SLD detail

Symmetry Locking Device Features

- ◆ Brushed Stainless Steel finish
- ◆ Fits 1 3/8" or 1 3/4" doors
- ◆ New construction or retrofit existing installations
- ◆ Made in the U.S.A.



Flush Door Frame for SLD Features

- ◆ Fits in a 39" rough opening with a 36" door slab
- ◆ Unfinished Poplar frames for up to 7" wall thickness
- ◆ Ambidextrous
- ◆ Custom sizes and materials available

* Running clearance and gate style will factor into meeting the 3" or 4" requirements